

Machine needle shut-off nozzle type-S

spring operated

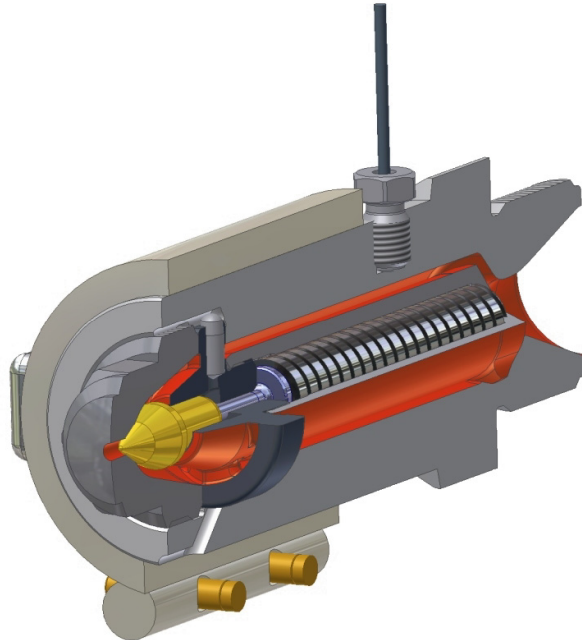

Applications:

Thermoplastics
(not applicable for PVC)

Shut-off mechanism:

Operated with one axial high performance spring

Index of contents

Chapter

	Page
1. Technical Description	2
2. Dimension sheet for orders or enquiries	3
3. Installation instructions.....	4
4. Nozzle design / Service	5
5. Integrated melt filter in S-Type nozzle	6
6. Spare part order form	7

1. Technical Description

The S-nozzles are used in the processing of thermoplastics. The nozzle size required depends on the injection rate per second (cm^3/s).

Clean shut-off of the melt and reliable closing during metering are the functions of an A-nozzle and an essential requirement for a smooth, reliable and economic production process.

The S-nozzle meets these requirements and has a compact, modular design, trouble-free operation and maximized flow geometry. The reliable shut-off system separates the melt flow at a predefined point determined by the process.

Systematic wear protection ensures a long life span. A filter module broadens the range of functions and possibilities of the S-nozzle.

What can you expect from the needle shut off nozzle type S?

- Disconnection of the melt stream at a definite point.
- Shorter cycle time ► Higher productivity
- Process reliability and repeatability
- Usable with increased back pressure ► improved homogenisation
- Adjustable opening pressure. Variable spring tensions.
- Easy assembly in a short time
- High operational safety
- Compact design
- All parts are interchangeable, easy disassembly
- Add-on capability (on tool side with; filter)

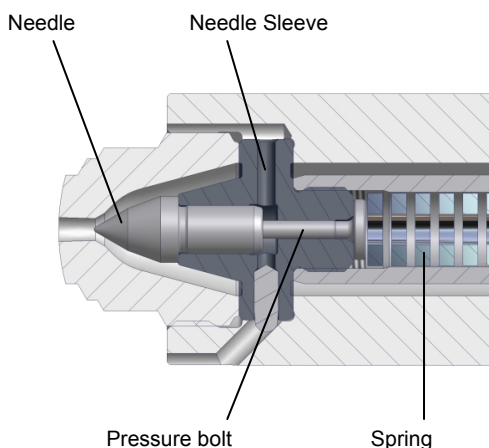

The spring operated needle shut-off machine nozzle (Type S) is opened directly from the injection pressure and closed again with spring power.

A needle which moves axially in the needle shut-off nozzle is held in the closed position by the force of the spring. The nozzle orifice is normally closed.

With the increasing melt pressure exerted against the spring through a ring of exposed surface area on the needle, the nozzle opens at **200 bar**. If the melt pressure drops (**80bar**), the nozzle closes.

If a different opening pressure is required, the pressurised ring area on the needle must be enlarged (lower opening pressure) or reduced (higher opening pressure). Modifications should not be made to the compression spring as this shortens its life.

A temperature-resistant material is used for the spring. (Heat-resistant to 520°C max.).

2. Dimension sheet for orders or enquiries

Company		Contact	
Street		Tel / Fax	
Zip/City		E-Mail	

Operating data	S0	S1	S2
max. injection flow rate cm ³ / s based on Polystyrol (PS)	45	500	1600
approx. worm diameter in mm	max. 20	20 -50	50 -120
opening and back pressure	200 bar		
max. injection pressure / temperature	2000 bar / 350°C		

<input type="checkbox"/> A0	<input type="checkbox"/> A1	<input type="checkbox"/> A2	Machine type	
-----------------------------	-----------------------------	-----------------------------	--------------	--

Filter module Standard filter gap A0=0.3 / A1=0.5 / A2=0.8 Abrasion protection (over 30% fillers)

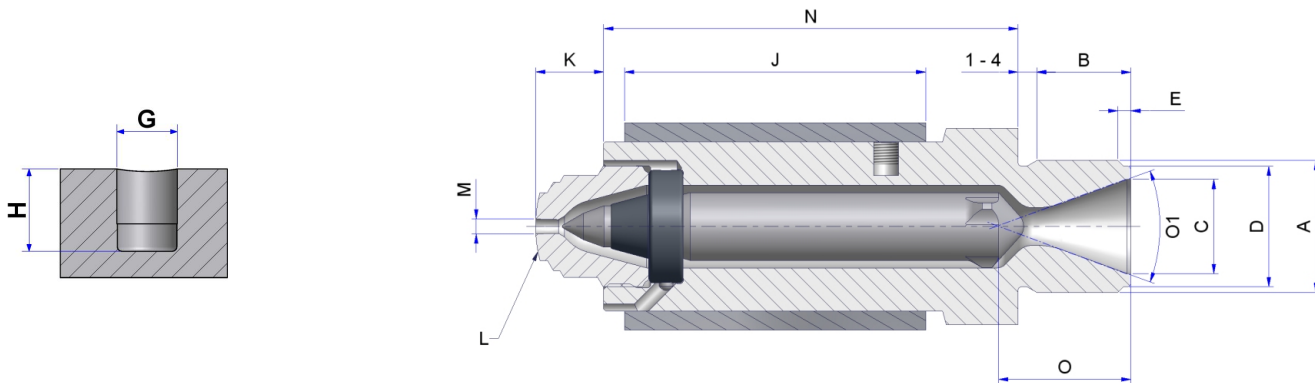

Standard dimensions	S0	S1	S2
K tip length installation wrench (AF)	15 19	18/28 24	30 41 (36)
M max. orifice	2,5 mm	5 mm	8 mm
N body length (excl. B) installation wrench (AF)	75 41	110 46	134 60
J heater band	Ø40x48 375 W	Ø45x60 480 W	Ø60x70 680 W

Your dimensions	Key	
	A	connection thread
	B	thread length incl. length of centering device (E)
	C	inlet diameter
	D	centering diameter
	E	length of centering device
	G	temperature sensor
	H	temperature sensor depth
	K	tip length (standard length above)
	L	tip radius
	M	nozzle tip orifice
	O / O1	check: immersion depth of screw tip / angle

Technical modifications reserved

We need additional information for requirements, which vary from our standard range e.g. drawing sample. Our customer services will be pleased to help you.



3. Installation and operation

Mounting

 **Maximum working conditions : 2000 bar at 350°C**

NOTE: Nozzle is supplied without heater band and temperature sensor. Can be supplied as an Option.

Legend

-  match temperatures
-  smear with high temperature paste

Mount nozzle according to the torque specified in the machine handbook.

Initial operation:

Heat nozzle to process temperature.

Repeated operation:

Melt the polymer fully in the nozzle.
First eject the heated material. This is done by extrusion at low speed (time 25 - 30 sec.) or by ejection at three to five times the injection time.

Production can begin when the nozzle temperature is the same as the melt temperature. When the machine is at rest, lower the nozzle temperature.

 Some plastics give off gases when they are left for a long time in stationary, heated nozzles. These can escape in an explosive fashion through the outlet hole.

Leakage:

A melt film is formed between the needle and its guide which prevents blockage of the needle. The melt film is continuously renewed and is finally discharged as minor leakage in the form of decomposed polymer. Major leakage means tolerance is too great (Standard 0.02mm).

A)

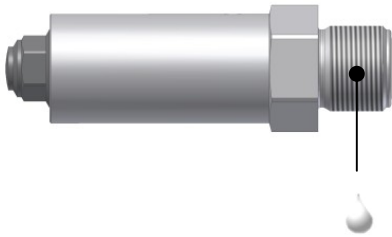

1. Grease sealing surfaces and threads with high temperature paste
2. Mount Nozzle incl. heater band and sensor

B)

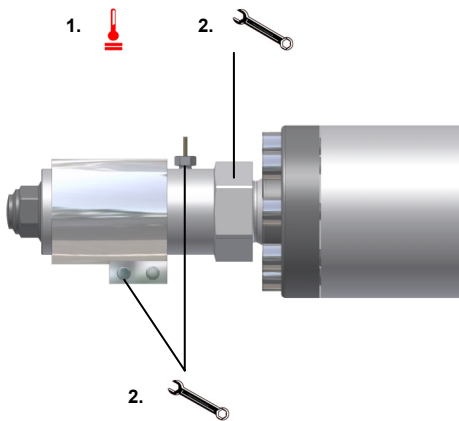

1. Match temperatures
2. Tighten
(torques: page 5)

4. Nozzle Design / Service

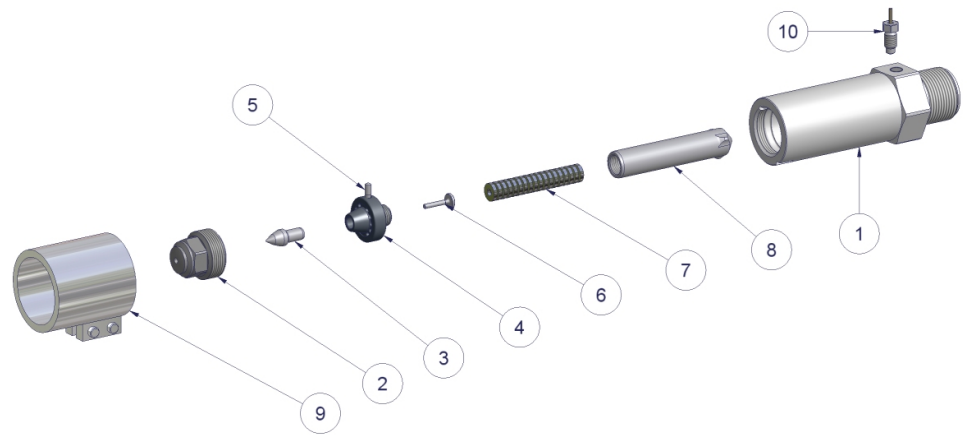

Assemble the nozzle according to the numerical order. Disassembling the opposite way around. Parts may vary according to customer specifications.

Procedure

1. Clamp the hexagonal part in a vice. Unscrew the tip
2. Remove shut-off parts using a punch
3. Insert the shut-off part reversed back into the body and reinsert positioning pin
4. Use a ring spanner on the three stabilisation extrusions to screw off spring chamber

Key	Quantity	Description
1	1	Body
2	1	Tip
3	1	Needle
4	1	Needle guide
5	1	Positioning pin
6	1	Pressure pin
7	1	Spring
8	1	Spring chamber
9	1	Heater band
10	1	Temperature sensor

Tools required



	S0	S1	S2
Tip - Hexagonal wrench:	AF 19 / 60Nm	AF 24 / 200Nm	AF 41(36) / 520Nm
Spring chamber - Ring spanner:	AF 11 / 20Nm	AF 19 / 40Nm	AF 25 / 50Nm

Help tools: punch, pliers, hammer

Before dismantling we recommend cleaning the nozzle in a fluidized-bed or ultrasonic cleaning tank. If cleaning equipment is not available, heat the nozzle with a band heater or gas torch and dismantle as described while it is hot. Clean individual parts with a wire brush.

Best results for nozzles used with materials like LCP, PPS or PEEK can be expected, if the nozzle is heated up to 500°C and hold it at that temperature level for about 2 hours. If you do so the material will burn.



Do not heat above 520°C ± 20°C !

Before reassembling lubricate all the threads with high temperature resistant grease. Check that all the parts are working correctly before reassembling. Check the seal surfaces for damage and the individual parts for wear.

Parts subject to wear

For optimum productivity you should always stock the following parts:
Spring, Heater band, Temperature sensor.

To order replacement parts see page 7.

Make the most of our inexpensive cleaning service. The nozzle is dismantled and checked by us.

5. Integrated melt filter in S-type nozzle

General

Added use of recycled material demands a final, important filtration directly before injecting. For a proper function of the mold (hot runner systems) a final filtration of the recycled material is imperatively needed.

The herzog® melt filter is based on the so called „gap filter principle“ and will be assembled into the existing spring operated shut-off nozzle without any modification.

Standard measurements of the filter gap:	Nozzle	S0 → 0.3 mm
		S1 → 0.5 mm
		S2 → 0.8 mm

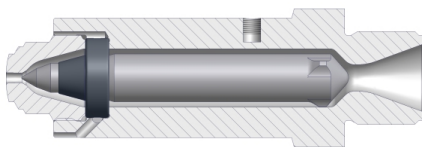

Standard System

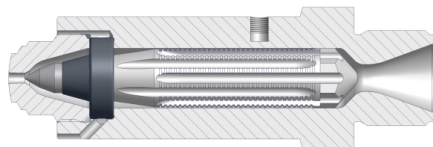

Filter System

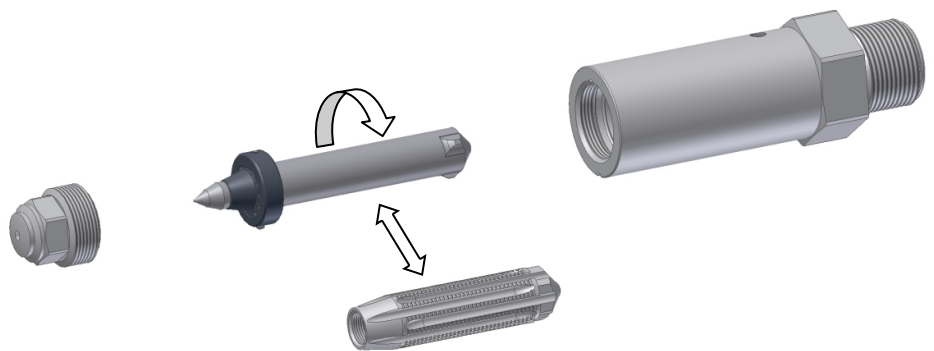

Interchangeable part

Retrofitting

Just by changing the standard spring chamber with a filter-spring chamber the retrofit is already done and the nozzle is again operational. Please disassemble the nozzle according to service sheet (page 5).

Cleaning

To clean the filter, the nozzle tip needs to be disassembled. Take shut-off unit out of the body together with the filter. Clean and install again.

Attention: Before tightening the tip, please pay attention to the fact that an equal temperature level between the tip and nozzle is needed. Torque on the tip according to service sheet (page 5).

For inquiries or orders please use the data sheet on page 3.

6. Spare parts order form

Your full contact information please:

Company	
Street	
Zip/City	
Contact	
Tel / Fax	
E-Mail	

Identity Nr. (marked on the hexagonal part)

Quantity	Part name / no. (see page 5)

Send to:

Xaloy Inc., 72 Stard Road, Seabrook NH 03874
Phone +603 929 82 46 / Fax +603 929 82 47
www.xaloy.com