

DeDuster | mini series



Bulkmatology™ fact: Clean pellets increase output, profitability and the quality of your end product

Discover **Bulkmatology™**
*The Art and Science of Bulk
Material Handling*

Mini DeDuster Features

- Patented air wash decks
- Patented venturi chamber
- Patented magnetic flux field coil
- Cast aluminum or stainless steel
- HEPA cartridge filter
- Hopper loader available
- Sight window
- Closed loop operation
- Metal detector available

Mini DeDuster Benefits

- Reduces scrap and bad parts
- Improves product quality
- Reduces maintenance
- Increases lifespan of the feed screw
- Increases use of regrind
- Improves production with a fast ROI

The Situation

Fines in virgin material and regrind heat up faster than the pellets and can burn or vaporize leaving defects in your end product.

The Solution

Remove fines with the Pelletron P1 or P5 DeDuster, made to fit directly to a molding machine, extruder or combined with a dryer. The DeDuster removes dust particles as small as 1 micron and as clean as 5 ppm.

The ROI

Calculate the individual return on investment by using Pelletron's online cost savings sheet.

Pelletron Corporation
499 Running Pump Road
Lancaster, PA 17601

Tel: 717.293.4008
Fax: 717.293.4011
info@pelletroncorp.com
www.pelletroncorp.com

pe:etron

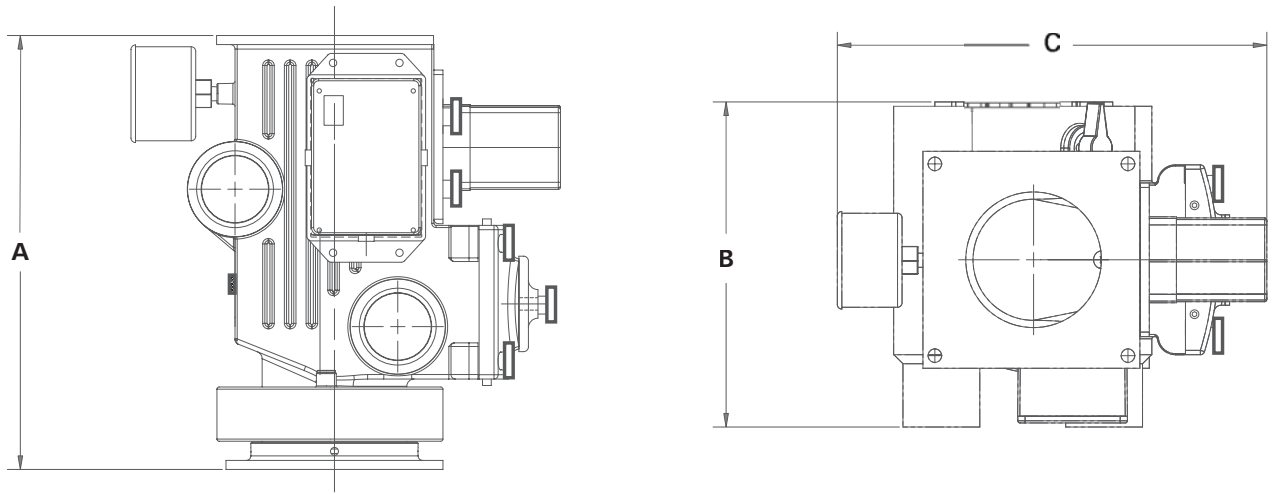

(all weights and measures are approximate)

Model	(A) Height	(B) Width	(C) Depth	Weight	Materials	Electrical Power	Capacity
P1 A	12.00 in 305 mm	9.00 in 230 mm	12.00 in 300 mm	13.8 lbs 6.3 kg	Aluminum housing Stainless wash deck	115VAC/230VAC 1 phase - 50/60 hz	Up to 150 lbs/hr Up to 70 kg/hr
P1 S	12.00 in 305 mm	9.00 in 230 mm	11.88 in 300 mm	18.1 lbs 8.2 kg	All Stainless	115VAC/230VAC 1 phase - 50/60 hz	Up to 150 lbs/hr Up to 70 kg/hr
P5	18.00 in 460 mm	13.75 in 350 mm	14.25 in 360 mm	36.6 lbs 16.6 kg	All Stainless	115VAC/230VAC 1 phase - 50/60 hz	151 to 500 lbs/hr 70 to 230 kg/hr

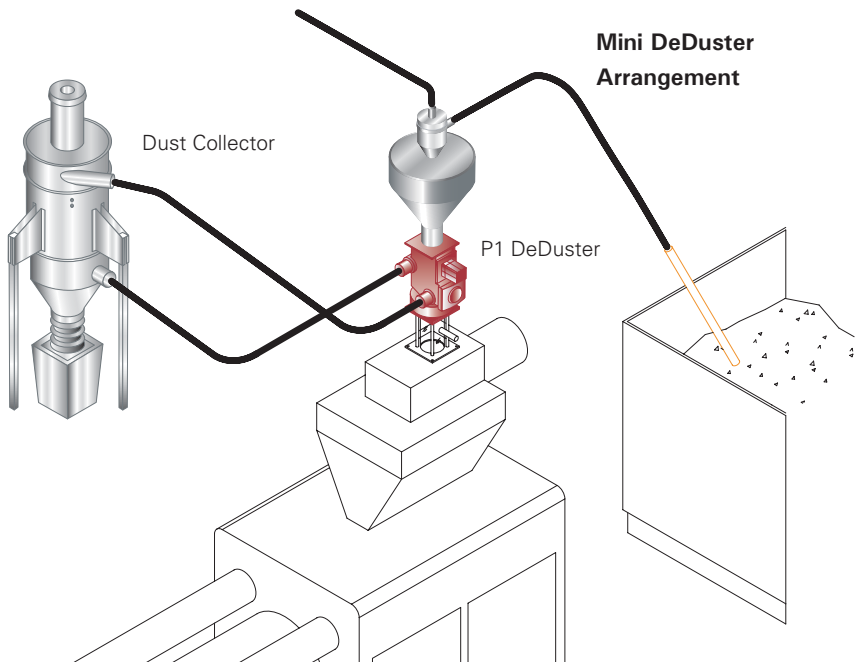

Principles of Operation

Product enters the DeDuster by gravity. The motorized agitator prevents material from bridging and controls the flow.

The fines are removed by the pressurized air wash deck and separated at the venturi chamber. A sight window allows the operator to monitor the cleaning action.

A magnetic flux field operating with 12V DC power, bathes the entire unit in a gentle, pulsing, magnetic field. This disrupts the static electricity and removes dust as small as 1 micron.

Clean pellets exit the DeDuster at the product outlet. The dusty air is drawn to a dust collector/fan package and flows through the high efficiency filter. The clean air is then returned to the wash air inlet.

Pelletron Corporation
499 Running Pump Road
Lancaster, PA 17601

Tel: 717.293.4008
Fax: 717.293.4011
info@pelletroncorp.com
www.pelletroncorp.com

